

WAC Air Curtains

Technical Guide

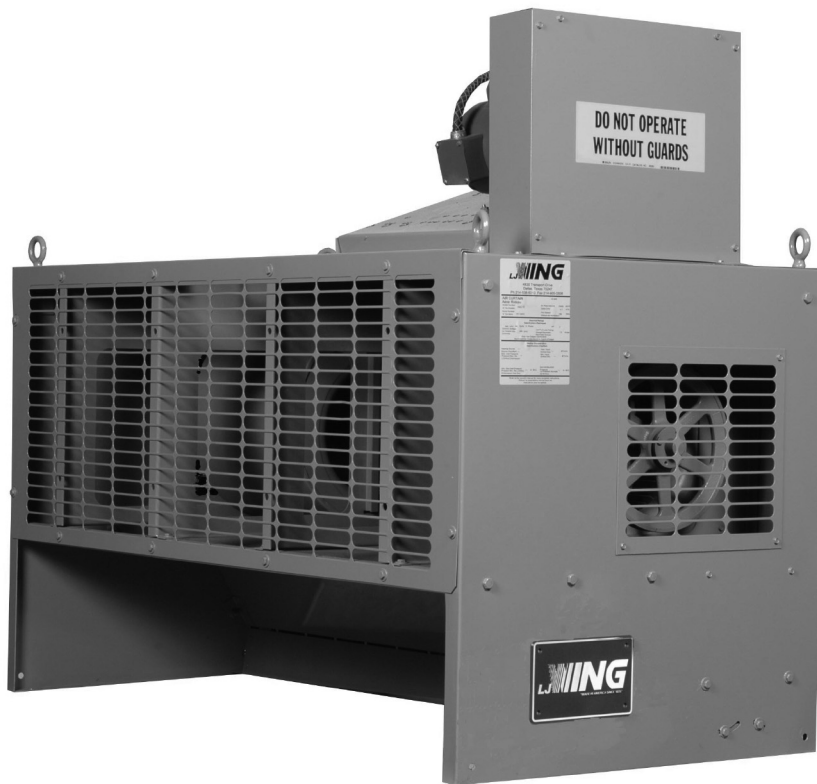

FOR WIND STOPPING, INSECT CONTROL, AND ENVIRONMENTAL SEPARATION IN COMMERCIAL AND INDUSTRIAL APPLICATIONS

LJ JING®

TABLE OF CONTENTS

Introduction2
Model Description2
Selection3
Performance4-7
Dimensions8-11
Electrical12-14
Specifications14-15
Schedule15

Introduction

Since 1875, the L.J. Wing Company has been a leader in providing innovative solutions for difficult HVAC problems. Wing WAC Air Curtains can offer protection against cold or hot outside air, outside wind, airborne insects, and airborne particles and contaminants. This technical guide will help you size, select and specify the proper WAC model to satisfy your project’s door protection requirements. If you have any questions, please contact your local L.J. Wing representative; they will be glad to assist you.

Model Description

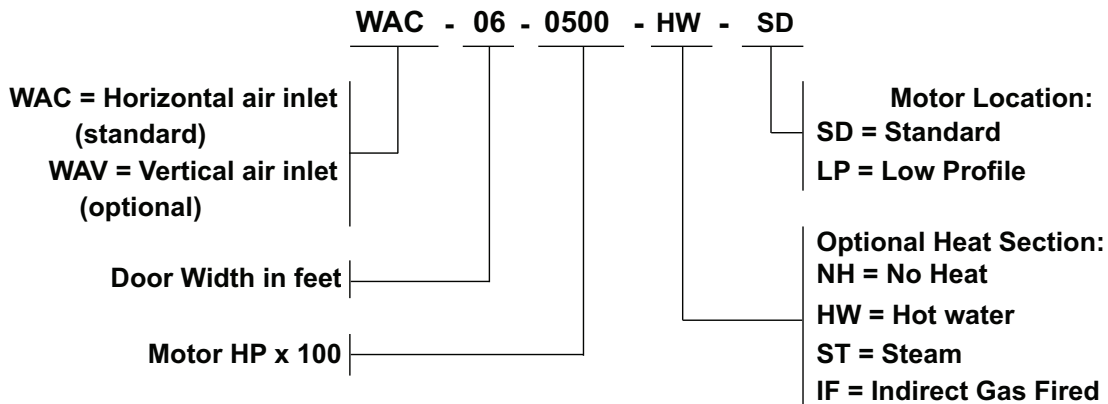

SELECTION

Selection Procedure and Example

Given:

- Door width and door height in feet.
- Design wind velocity in mph.
- If applicable, type of optional heating source: steam coil, hot water coil, indirect fired gas furnace.
- Electrical service characteristics in volts/phase/hertz.

Procedure:

1. Select WAC model size and airflow in cfm from Selection Table below. In many instances, more than one airflow selection will be applicable.
2. Determine the external static pressure requirement as the sum of the static pressure losses of any optional accessories, including filters, steam coil or hot water coil from page 5, or indirect-fired gas furnace from page 6.
3. Using the CFM of step 1 and the external static pressure calculated in Step 2, look up the required motor horsepower from the Fan Performance table on page 7.
4. Referring to the drawing on page 8, choose whether the standard or low profile motor location is desired.

5. Construct the model number using the description shown at the bottom of page 2.

Example:

Given:

- Door width = 14 feet; Door height = 15 feet.
- Design velocity = 9 mph.
- Steam heat with 5 psig pressure.
- Electrical Service = 230volt/3 phase/60 Hz.

Procedure:

1. From Selection Table, the proper selection is a size 14 air curtain with airflow of 16,743 cfm, suitable for door heights of 12 to 17 feet in an 8-10 mph wind.
2. From Steam and Hot Water coil data table on page 5, Coil static pressure drop = 0.41 inches w.c.
3. From Motor HP table on page 7 for a WAC-14 delivering 16,743 cfm with an external static pressure drop of 0.41 inches w.c.: Two each 7.5 HP motors are required.
4. The standard motor location is chosen.
5. The full model number is thus:
WAC - 14 – 1500 – ST – SD.

Selection Table

Size	Airflow Rate (CFM)	Door Height in Feet at 8-10 mph wind	Door Height in Feet at 12-15 mph wind
04	2,775	Under 10	Under 10
	3,177	10-11	
	3,496	12-17	10-11
	4,002		12-17
	4,405		12-17
5,043	18-20	12-17	
05	3,672	Under 12	Under 10
	4,041		10-11
	4,626	12-17	12-17
	5,092		12-17
	5,828		12-17
6,910	18-20	18-20	
06	4,347	Under 10	Under 10
	4,784		Under 10
	5,477	10-17	10-11
	6,028		10-11
	6,900		12-17
8,181	18-20	12-17	
9,365		18-20	
07	4,896	Under 10	Under 10
	5,604		10-11
	6,168	10-17	12-17
	7,061		12-17
	8,371		12-17
9,583	18-20	18-20	
10,547		18-20	
08	6,354	Under 10	Under 10
	6,993		10-11
	8,005	10-17	12-17
	9,491		12-17
	10,864		12-17
11,958	18-20	18-20	

Size	Airflow Rate (CFM)	Door Height in Feet at 8-10 mph wind	Door Height in Feet at 12-15 mph wind
09	7,816	Under 12	Under 10
	8,947		10-11
	10,608	12-17	12-17
	12,143		12-17
	13,366		12-17
10	9,123	Under 12	Under 10
	10,816		10-11
	12,381	12-20	12-17
	13,628		12-20
	15,600		12-20
12	9,569	Under 10	Under 10
	10,953	10-11	
	12,987	12-17	10-11
	14,866		12-17
	16,362		12-17
18,730	18-20	18-20	
14	11,208	Under 12	Under 10
	12,336		10-11
	14,121	12-17	10-11
	16,743		12-17
	19,166		12-17
21,095	18-20	18-20	
16	12,707	Under 10	Under 10
	13,986		10-11
	16,010	10-17	12-17
	18,982		12-17
	21,729		12-17
23,916	17-20	18-20	

PERFORMANCE

AMCA Certified Ratings

Size	Model	Airflow Rate (CFM)	Outlet Velocity (FPM)	Power Rating (watts)	Outlet Velocity Uniformity (%)
04	04-0050	2,775	1,931	537	94.4
	04-0075	3,177	2,210	762	94.4
	04-0100	3,496	2,432	989	94.4
	04-0150	4,002	2,784	1,472	94.4
	04-0200	4,405	3,065	1,860	94.4
	04-0300	5,043	3,508	2,746	94.4
05	05-0075	3,672	2,073	762	90.0
	05-0100	4,041	2,282	989	90.0
	05-0150	4,626	2,612	1,472	90.0
	05-0200	5,092	2,875	1,860	90.0
	05-0300	5,828	3,291	2,746	90.0
	05-0500	6,910	3,902	4,571	90.0
06	06-0075	4,347	2,066	762	91.4
	06-0100	4,784	2,274	989	91.4
	06-0150	5,477	2,603	1,472	91.4
	06-0200	6,028	2,865	1,860	91.4
	06-0300	6,900	3,279	2,746	91.4
	06-0500	8,181	3,888	4,571	91.4
	06-0750	9,365	4,451	6,749	91.4
07	07-0100	4,896	2,055	989	90.0
	07-0150	5,604	2,353	1,472	90.0
	07-0200	6,168	2,590	1,860	90.0
	07-0300	7,061	2,964	2,746	90.0
	07-0500	8,371	3,515	4,571	90.0
	07-0750	9,583	4,023	6,749	90.0
	07-1000	10,547	4,428	8,715	90.0
08	08-0150	6,354	2,270	1,472	91.4
	08-0200	6,993	2,499	1,860	91.4
	08-0300	8,005	2,860	2,746	91.4
	08-0500	9,491	3,391	4,571	91.4
	08-0750	10,864	3,882	6,749	91.4
	08-1000	11,958	4,273	8,715	91.4

Size	Model	Airflow Rate (CFM)	Outlet Velocity (FPM)	Power Rating (watts)	Outlet Velocity Uniformity (%)
09	09-0200	7,816	2,611	1,860	90.0
	09-0300	8,947	2,989	2,746	90.0
	09-0500	10,608	3,544	4,571	90.0
	09-0750	12,143	4,057	6,749	90.0
	09-1000	13,366	4,466	8,715	90.0
10	10-0300	9,123	2,654	2,746	91.4
	10-0500	10,816	3,147	4,571	91.4
	10-0750	12,381	3,602	6,749	91.4
	10-1000	13,628	3,964	8,715	91.4
	10-1500	15,600	4,538	12,440	91.4
12	12-0200	9,569	2,274	1,860	91.4
	12-0300	10,953	2,603	2,746	91.4
	12-0500	12,987	3,086	4,571	91.4
	12-0750	14,866	3,532	6,749	91.4
	12-1000	16,362	3,888	8,715	91.4
14	14-0300	11,208	2,353	2,944	90.0
	14-0400	12,336	2,590	3,720	90.0
	14-0600	14,121	2,964	5,492	90.0
	14-1000	16,743	3,515	9,142	90.0
	14-1500	19,166	4,023	13,498	90.0
16	16-0300	12,707	2,270	2,944	91.4
	16-0400	13,986	2,499	3,720	91.4
	16-0600	16,010	2,860	5,492	91.4
	16-1000	18,982	3,391	9,142	91.4
	16-1500	21,729	3,882	13,498	91.4
16-2000	23,916	4,273	17,430	91.4	

Notes:

① Sizes 14 and 16 use two motors of identical size. For example; the model 14-0600 uses two 3 HP motors.

Velocity Projection (model WAC-6)

Velocity (FPM)	Distance from nozzle (inches)
6070	4
2765	36
1685	120
1375	204

NOTES:

- The ratings data shown above only applies to base (unheated) WAC and WAV units at free delivery (External static pressure = 0.0" inches W.C.).

PERFORMANCE

Steam and Hot Water Coils

Size	CFM	Steam Coil *		Hot Water Coil **		Static Pressure Loss (Inches w.c.)
		Heat Transfer (MBH)	Delta T (Degrees F)	Heat Transfer (MBH)	Delta T (Degrees F)	
04	2,775	179	59	123	41	0.13
	3,177	194	56	135	39	0.17
	3,496	204	53	143	37	0.20
	4,002	220	50	157	36	0.26
	4,405	231	48	167	34	0.31
	5,043	248	45	181	33	0.39
05	3,672	232	58	163	41	0.15
	4,041	245	56	174	40	0.18
	4,626	264	52	190	38	0.22
	5,092	278	50	202	37	0.27
	5,828	298	47	220	35	0.34
	6,910	325	43	244	33	0.46
06	4,347	276	58	196	41	0.15
	4,784	291	56	209	40	0.17
	5,477	314	52	228	38	0.22
	6,028	330	50	242	37	0.26
	6,900	355	47	264	35	0.33
	8,181	387	43	294	33	0.45
	9,365	413	40	319	31	0.57
07	4,896	313	59	224	42	0.14
	5,604	338	55	245	40	0.18
	6,168	356	53	260	39	0.22
	7,061	383	50	284	37	0.27
	8,371	418	46	316	35	0.37
	9,583	447	43	343	33	0.47
	10,547	469	41	363	32	0.56
08	6,354	390	56	284	41	0.17
	6,993	411	54	302	39	0.20
	8,005	442	50	329	37	0.25
	9,491	483	46	366	35	0.34
	10,864	518	43	398	33	0.44
	11,958	543	41	422	32	0.52
09	7,816	451	53	334	39	0.21
	8,947	485	50	364	37	0.27
	10,608	530	46	405	35	0.37
	12,143	567	43	440	33	0.47
	13,366	594	41	466	32	0.56
10	9,123	523	52	390	39	0.22
	10,816	573	48	434	37	0.30
	12,381	614	45	465	34	0.38
	13,628	645	43	494	33	0.45
	15,600	687	40	529	31	0.57
12	9,569	567	54	407	39	0.19
	10,953	610	51	444	37	0.25
	12,987	667	47	495	35	0.33
	14,866	715	44	539	33	0.42
	16,362	749	42	571	32	0.50
	18,730	800	39	619	30	0.64
14	11,208	658	54	478	39	0.20
	12,336	693	52	508	38	0.24
	14,121	745	48	554	36	0.30
	16,743	813	45	616	34	0.41
	19,166	869	42	669	32	0.52
	21,095	910	40	708	31	0.62
16	12,707	763	55	557	40	0.18
	13,986	805	52	592	39	0.22
	16,010	865	49	646	37	0.28
	18,982	945	45	718	34	0.37
	21,729	1,011	42	780	33	0.48
	23,916	1,060	40	827	31	0.56

*Steam coil performance based on 2 row, 6 fpi coil at 5 psi and 60 degree EAT.

**HW coil performance based on 2 row, 6 fpi coil at 200 EWT/180 LWT and 60 degree EAT.

For steam or HW coil performance at other conditions, consult factory.

PERFORMANCE

Indirect Fired Heaters

Size	CFM	Heater Size	# of Heaters	MBH Output	Delta T (degrees F)	Static Pressure loss (Inches w.c.)
04	2,775	QVED-200	1	160	53	0.28
	3,177				47	0.35
	3,496				42	0.43
	4,002				37	0.53
	4,405				34	0.69
5,043	29	0.90				
05	3,672	QVED-350	1	280	71	0.15
	4,041				64	0.21
	4,626				56	0.27
	5,092				51	0.31
	5,828				44	0.40
6,910	38	0.59				
06	4,347	QVED-350	1	280	60	0.22
	4,784				54	0.30
	5,477				47	0.38
	6,028				43	0.45
	6,900				38	0.60
8,181	32	0.80				
9,365	28	1.05				
07	4,896	QVED-400	1	320	61	0.23
	5,604				53	0.30
	6,168				48	0.36
	7,061				42	0.46
	8,371				35	0.68
9,583	31	0.86				
10,547	28	1.04				
08	6,354	QVED-250	2	400	58	0.25
	6,993				53	0.29
	8,005				46	0.35
	9,491				39	0.50
	10,864				34	0.65
11,958	31	0.79				
09	7,816	QVED-300	2	480	57	0.27
	8,947				50	0.32
	10,608				42	0.46
	12,143				37	0.59
	13,366				33	0.73
10	9,123	QVED-350	2	560	57	0.28
	10,816				48	0.36
	12,381				42	0.49
	13,628				38	0.58
	15,600				33	0.72
12	9,569	QVED-400	2	640	62	0.20
	10,953				54	0.29
	12,987				46	0.39
	14,866				40	0.52
	16,362				36	0.62
18,730	32	0.81				
14	11,208	QVED-300	3	720	59	0.21
	12,336				54	0.29
	14,121				47	0.35
	16,743				40	0.49
	19,166				35	0.65
21,095	32	0.84				
16	12,707	QVED-350	3	840	61	0.22
	13,986				56	0.28
	16,010				49	0.33
	18,982				41	0.49
	21,729				36	0.61
23,916	32	0.73				

DIMENSIONS

Air Curtain with Optional Heating Coil

C000617A

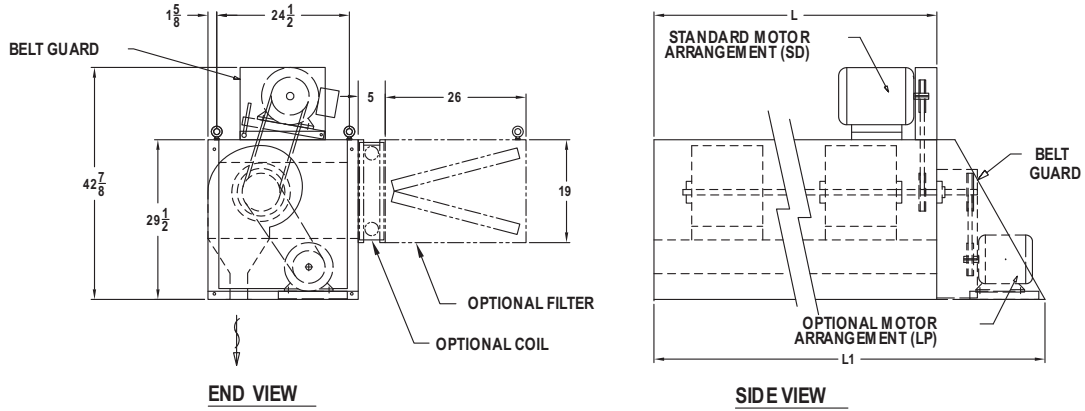

SIZE	L	L1	QTY BLOWERS
04	52	68	2
05	64	80	3
06	76	92	3
07	86	102	4
08	101	117	4
09	108	130	5
10	124	146	5
12	152	174	6
14	172	216	8
16	202	246	8

NOTES: 1. UNIT WITH HORIZONTAL AIR INLET (MODEL WAC) SHOWN;
UNIT WITH TOP VERTICAL AIR INLET (MODEL WAV) OPTIONAL.
2. ALL DIMENSIONS IN INCHES.

Weights

Size	Base Unit	Heating Coil	Filter Section	Gas Heater Section
04	375	67	115	232
05	480	79	135	389
06	530	92	160	389
07	615	102	170	403
08	660	118	190	526
09	750	125	200	624
10	792	141	225	778
12	1056	174	320	806
14	1224	194	340	936
16	1320	226	380	1167

Note: All weights in pounds.

DIMENSIONS

Air Curtain with One Indirect-Fired Furnace

C000618B

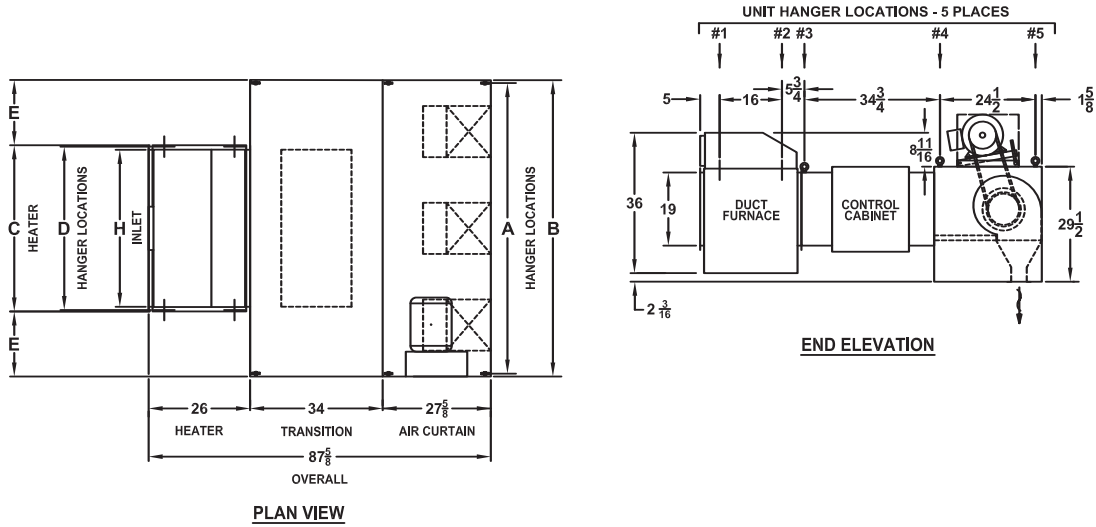

SIZE	HEATER MODEL	QTY	A	B	C	D	E	H	BLOWER QUANTITY
04	QVED-200	1	50 ³ / ₄	52	26 ¹ / ₈	25 ³ / ₈	12 ¹⁵ / ₁₆	23 ³ / ₄	2
05	QVED-350	1	62 ³ / ₄	64	42 ⁵ / ₈	41 ⁷ / ₈	10 ¹¹ / ₁₆	40 ¹ / ₄	3
06	QVED-350	1	74 ³ / ₄	76	42 ⁵ / ₈	41 ⁷ / ₈	16 ¹¹ / ₁₆	40 ¹ / ₄	3
07	QVED-400	1	84 ³ / ₄	86	48 ¹ / ₈	47 ³ / ₈	18 ¹⁵ / ₁₆	45 ³ / ₄	4

- NOTES: 1. ALL DIMENSIONS ARE IN INCHES.
 2. ABOVE DRAWING ILLUSTRATES NUMBER OF BLOWERS PROVIDED FOR WAC-05. REFER TO ABOVE TABLE FOR QUANTITY OF BLOWERS PROVIDED IN OTHER MODELS.
 3. DUCT FURNACE VENT CONNECTION SIZE IS 5" FOR SIZE 04 AND 6" FOR SIZE 05, 06 AND 07.

DIMENSIONS

Air Curtain with Two Indirect-Fired Furnaces

C000619B

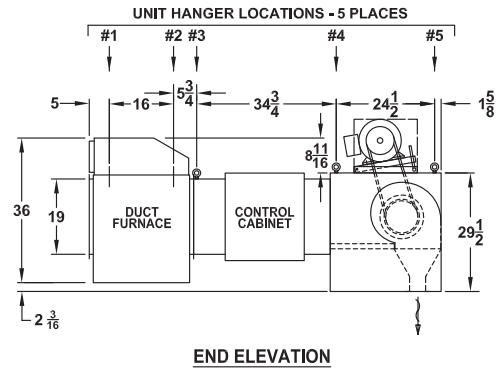
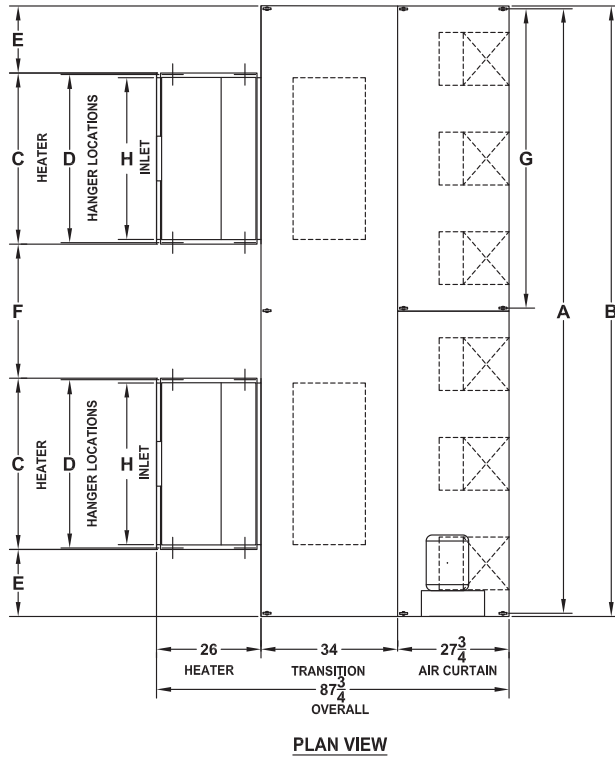

SIZE	HEATER MODEL	QTY	A	B	C	D	E	F	G	H	QTY BLOWERS
08	QVED-250	2	99 ³ / ₄	101	31 ⁵ / ₈	30 ⁷ / ₈	9 ⁷ / ₁₆	18 ⁷ / ₈	-	29 ¹ / ₄	4
09	QVED-300	2	106 ³ / ₄	108	37 ¹ / ₈	36 ³ / ₈	8 ⁷ / ₁₆	16 ⁷ / ₈	-	34 ³ / ₄	5
10	QVED-350	2	122 ³ / ₄	124	42 ⁵ / ₈	41 ⁷ / ₈	9 ¹¹ / ₁₆	19 ³ / ₈	-	40 ¹ / ₄	5
12	QVED-400	2	150 ³ / ₄	152	48 ³ / ₈	47 ³ / ₈	13 ⁵ / ₁₆	27 ⁷ / ₈	74 ³ / ₄	45 ³ / ₄	6

- NOTES: 1. ALL DIMENSIONS ARE IN INCHES.
 2. ABOVE DRAWING ILLUSTRATES NUMBER OF BLOWERS PROVIDED FOR WAC-12;
 REFER TO ABOVE TABLE FOR QUANTITY OF BLOWERS PROVIDED IN OTHER MODELS.

DIMENSIONS

Air Curtain with Three Indirect-Fired Furnaces

C000620A

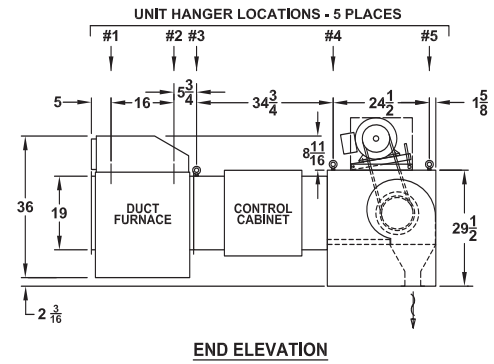
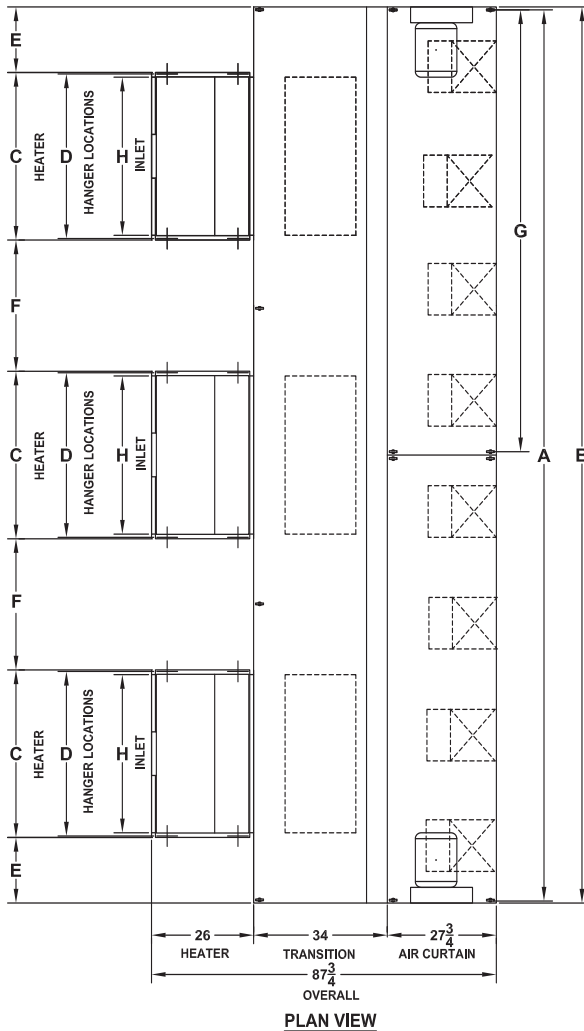

SIZE	HEATER MODEL	QTY	A	B	C	D	E	F	G	H	QTY BLOWERS
14	QVED-300	3	170 ³ / ₄	172	37 ¹ / ₈	36 ³ / ₈	10 ³ / ₁₆	20 ¹ / ₈	84 ³ / ₄	34 ³ / ₄	8
16	QVED-350	3	200 ³ / ₄	202	42 ⁵ / ₈	41 ⁷ / ₈	12 ⁷ / ₁₆	24 ⁵ / ₈	99 ³ / ₄	40 ¹ / ₄	8

NOTE: ALL DIMENSIONS ARE IN INCHES.

ELECTRICAL

Wiring Diagram

C000623

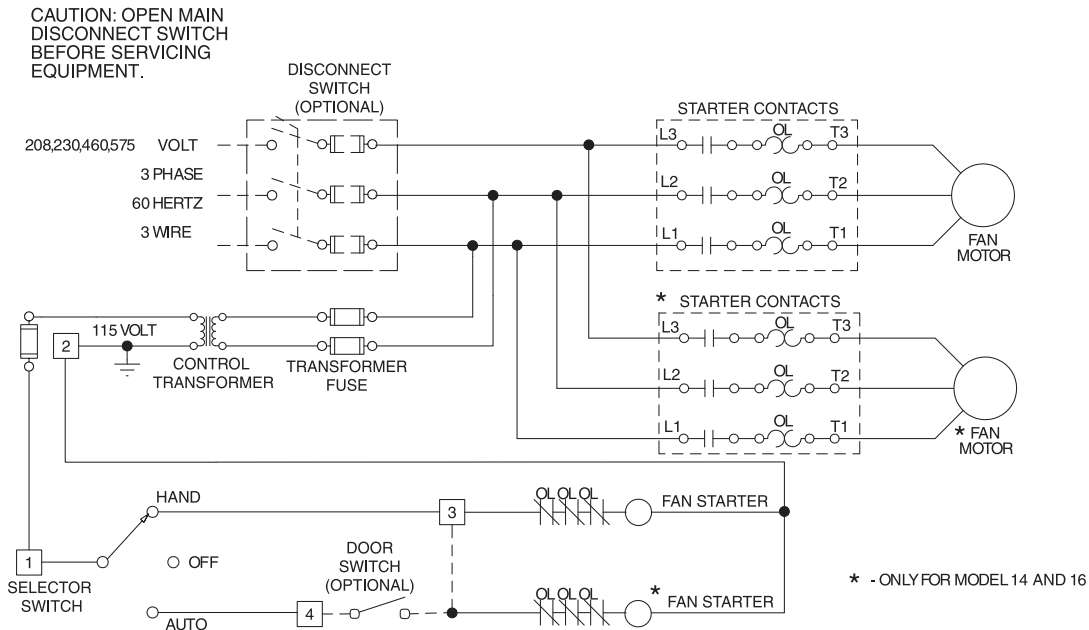

Controls

WAC Air Curtains without optional gas heating are shipped as standard without controls. Motor(s) for such units are mounted on adjustable bases with leads for easy field connections.

A factory-wired control panel is available as an option, complete with NEMA 1 enclosure, magnetic motor starter, overload relay heaters, disconnect switch, 120-volt transformer, terminal strip, and a Hand-Off-Auto switch.

For automatic control with the Hand-Off-Auto switch, two additional options are available: a room thermostat or a door switch. Each of these options must be mounted and wired by others. In the case of a door switch, the air curtain would be wired so that it runs when the door is open.

The Hand-Off-Auto switch is mounted on the face of the control panel. When in the "Hand" position, the air curtain runs regardless of the position of the door switch or room thermostat. When in the "Automatic" position, the air curtain will cycle on and off at the control of the door switch or room thermostat.

ELECTRICAL

Wiring Diagram for Unit with Gas Furnaces

C000622

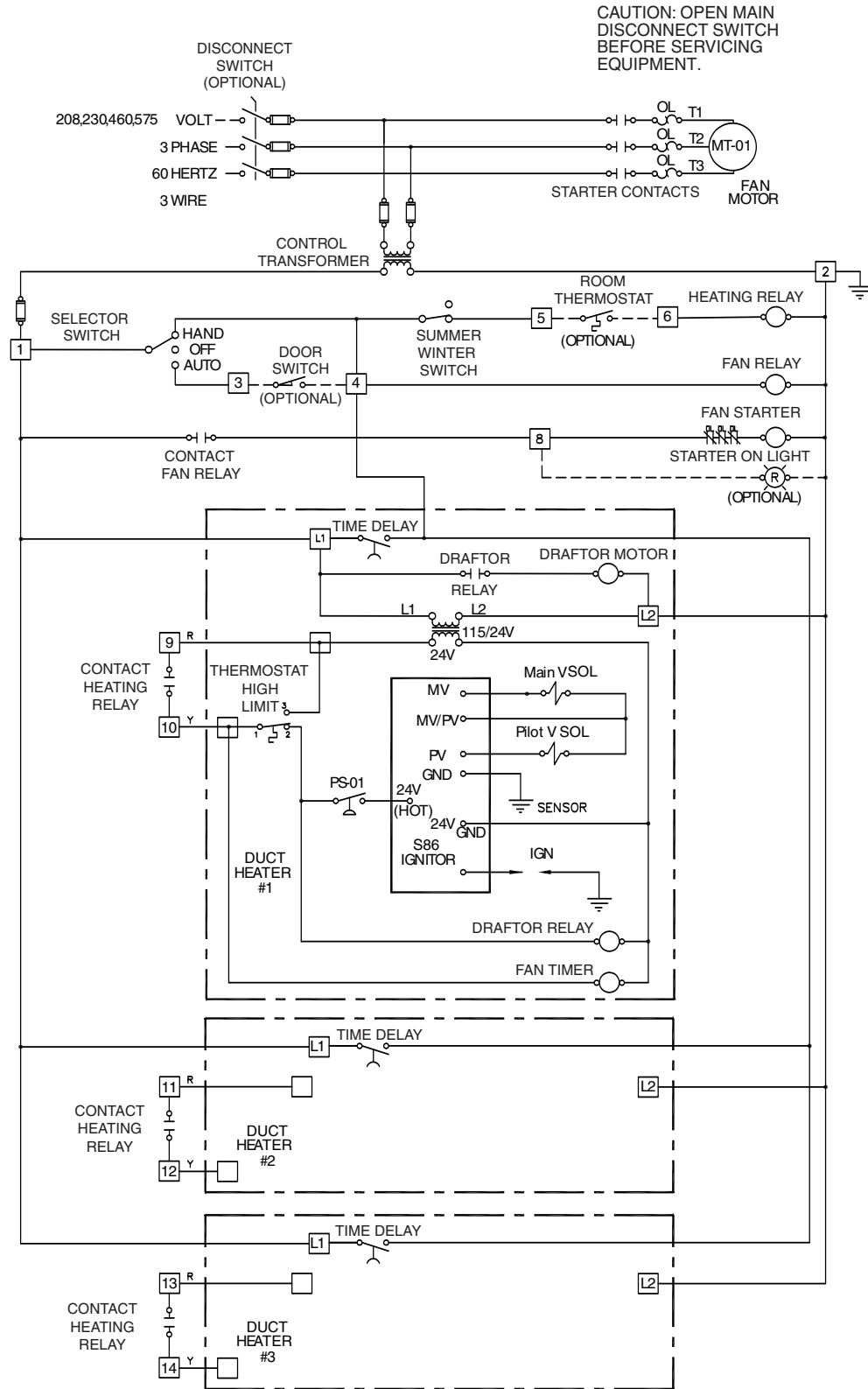

ELECTRICAL

Amp Draw Table

ITEM	SOURCE	ELECTRICAL SERVICE	MOTOR AMPS AT GIVEN MOTOR HORSEPOWER											
			1/2	3/4	1	1 1/2	2	3	5	7 1/2	10	15	20	25
A	Blower Motor	208V 3 Ph	2.4	3.5	4.6	6.6	7.5	10.6	16.7	24.2	30.8	46.2	59.4	74.8
		230V 3 Ph	2.2	3.2	4.2	6.0	6.8	9.6	15.2	22.0	28.0	42.0	54.0	68.0
		460V 3 Ph	1.1	1.6	2.1	3.0	3.4	4.8	7.6	11.0	14.0	21.0	27.0	34.0
		575V 3 Ph	0.9	1.3	1.7	2.4	2.7	3.9	6.1	9.0	11.0	17.0	22.0	27.0
B	Control Transformer	ELECTRICAL SERVICE	CONTROL CIRCUIT AMPS											
			W/O GAS HEATER(S)						WITH GAS HEATER(S)					
		208V 3 Ph	0.5						7.2					
		230V 3 Ph	0.4						6.5					
		460V 3 Ph	0.2						3.3					
		575V 3 Ph	0.2						2.6					

NOTES:

1. Above motor amps are based on 2002 edition of NEC.
2. Control circuit amps are based on standard controls.

Steps to size optional disconnect switch:

1. Using the required blower motor HP and the given electrical service, look up the blower motor amp draw from Item A in the above chart.
2. Look up the control circuit amps for the unit gas heater configuration from Item B in above chart.
3. Add Blower Motor amps from Step 1 to Control Circuit amps of Step 2, then multiply result by 1.25 to get required size of optional disconnect switch.

Specification

General

Furnish L.J. Wing model WAC air curtain(s) with performance as shown on the schedule. Air curtains shall be suited for blanketing the door widths listed on the schedule, and include a minimum overlap of two inches on both sides of the door to sweep the outer edges of the door opening.

Fan and Motor Assembly

Provide belt drive motors so that velocity can be maintained through the use of adjustable sheaves. Baffles in the discharge chamber used to adjust velocity while increasing pressure drop are not acceptable. One motor shall be used for air curtains up to twelve feet long; longer air curtains shall have a maximum of two motors.

Motors are to be mounted outside of the airstream (on top of the casing)(on end for low profile), thus eliminating the need for air diverters. Motors shall be (open drip-proof) (totally enclosed fan-cooled) type and be easily accessible for maintenance without any disassembly of the air curtains. Units with three phase motor(s) 1 HP and larger will have Energy Efficient motor(s).

Blowers shall be centrifugal forward curved type, complete with housings. Blowers shall be tested in accordance with standards set forth in AMCA Standard 210. Blower wheels and housings are to be constructed of painted cold rolled steel. Wheels are to be statically and dynamically balanced. Blower speeds shall not exceed 1,500 rpm.

Casing

Unit shall be constructed with 11 gauge galvanized steel frame, and have sufficient rigidity such that the deflection across its entire length shall not exceed 1/4 inch. Casings are to be built with 18 gauge, galvanized steel. Casings shall have means of attaching hangers, and be equipped with removable panels for access to bearings, couplings and other internal components.

An inlet screen is to be furnished on front of the unit for direct air intake. Multiple inlet screens on top of the unit shall be provided for the purpose of air recirculation.

SPECIFICATION AND SCHEDULE

Specification, cont.

Plenum/Discharge

Provide a tapered plenum at least ten inches long on the discharge of the blowers. A discharge nozzle at least four inches wide shall be included to distribute the outlet air. The outlet air velocity pattern shall have a uniformity of better than 90% over the entire length of the air curtain. Uniformity from the discharge nozzle shall be accomplished without the use of air diverters. Discharge nozzles shall be field adjustable to plus or minus fifteen degrees with no objects, dampers, or grilles included to add turbulence or create a pressure drop in the airstream.

The unit design shall allow for the addition of heating sections or filters without altering the base unit.

Optional Accessories

A. Provide a factory-wired control panel that includes the following items:

- NEMA 1 enclosure (NEMA 12 enclosure)
- Magnetic motor starter
- Overload relay heaters
- Disconnect switch
- 120 volt transformer
- Terminal strip
- Hand-Off-Auto switch in cover

Control panels to be remote mounted (unit-mounted)(unit-mounted and wired to motor). (Control panel shall be U.L. listed).

B. Provide steam or hot water heating coil constructed of two rows of minimum 0.020 inch thick wall copper tubing mechanically expanded into minimum 0.006 inch thick, full collar aluminum fins spaced at six fins per inch. Coil face velocity shall not exceed 1,200 fpm. Coils are to be rated at 125 psig operating pressure and tested at 400 psig.

C. Provide AGA-certified indirect-fired furnaces of the capacities as indicated on the schedule. Unit shall include a transition section between the furnace outlet and air curtain inlet. The duct furnaces shall include a (single stage) (two stage) gas valve. The heat exchanger is to be constructed of (aluminized steel) (409 stainless steel). Provide unit for induced draft fans. Duct furnaces are to be provided with automatic spark ignition. Fuel supply to be natural gas (propane).

D. Filter section with disposable filters.

E. Painted galvanized casing.

F. Door switch.

G. On-off room thermostat.

H. Vibration hangers

Schedule

From Example on page 3:

Model No.	Airflow (cfm)	External Static Pressure (inches w.c.)	Motor HP	Steam Pressure (psig)	Heat Transfer, MBTUH	Delta T (Degrees F)	Electrical Volts/phase/HZ	Tag
WAC-14-1500-ST-SD	16,743	0.41	2@7.5	5	813	45	230/3/60	DAC-1



4830 Transport Drive, Dallas, TX 75247
Tel. (214) 638-6010 Fax (214) 905-0806
www.ljwing.com